

# Direct Injection Box for Recording & PA Systems

Rod Elliott (ESP)  
Updated 08 Jan 2005

---

## Introduction

A Direct Injection (or DI) box is a very handy piece of equipment for any public address rig or recording studio, whether for band or general use. It will allow you to connect the output from guitar amps, keyboard mixers, tape machines and just about anything else directly to the mixer, without using a microphone, and with no hum loops.

The unit described will convert unbalanced inputs (such as from a guitar or bass amp) to balanced, allows the level to be set to something reasonable, and comes in two flavours. There is a completely passive version that uses a transformer to create the balanced send, or an active unit which can be operated from a 48V phantom feed or a couple of 9V batteries.

---

## Description

Firstly, for those who may not know about phantom feed, Figure 1 shows how it is done. The 48V supply in the mixer is connected to both signal lines, so causes no current flow in transformers since both ends of the winding are at the same DC potential. At the remote end, the current is tapped off the lines using a resistance value suitable for the electronics. Again, this is done with both signal lines to ensure that there is no DC imbalance in the circuit.

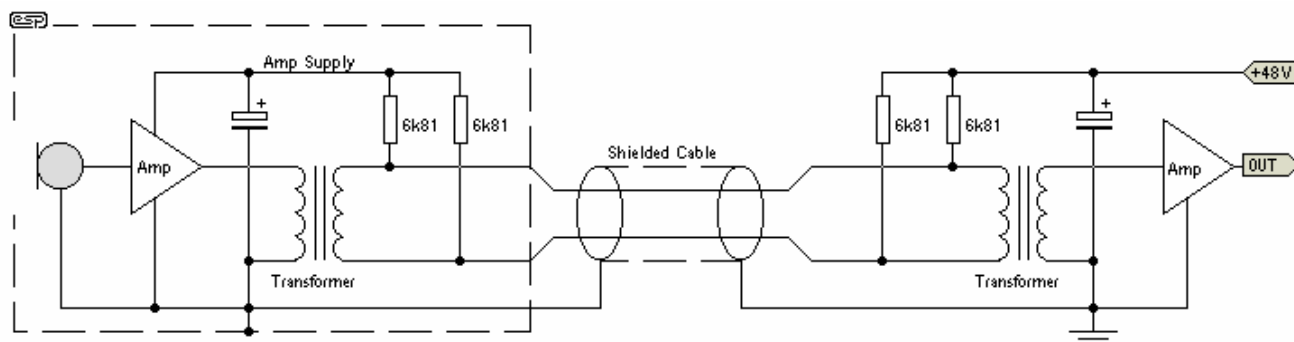

Figure 1 - Phantom Powering

After filtering (and in some cases regulation as well), the DC is then available to power the circuit that drives the AC signal down the very same pair that provides the power. In all cases the shield must be connected at both ends, since this provides the DC return path (hence no earth lift switch). In this example a microphone has been used, but the same concept applies to virtually anything that can function on the limited power available.

Figure 2 is the passive version of the DI Box, which is very easy to build. The only problem is that to get good sound quality, you will need a good transformer, and these are expensive. As can be seen, the input is simply two 6.5mm phone jacks to

allow a speaker lead to pass through the unit. The output is a male XLR connector, and is balanced. Have a look at the Jensen Transformers (or any other audio transformer manufacturer) web site to track down a suitable unit. There are many other manufacturers, but I don't know them all. See if you can find one in your country. The transformer is 1:1 ratio, and needs to be rated for 600 ohm operation (or higher).

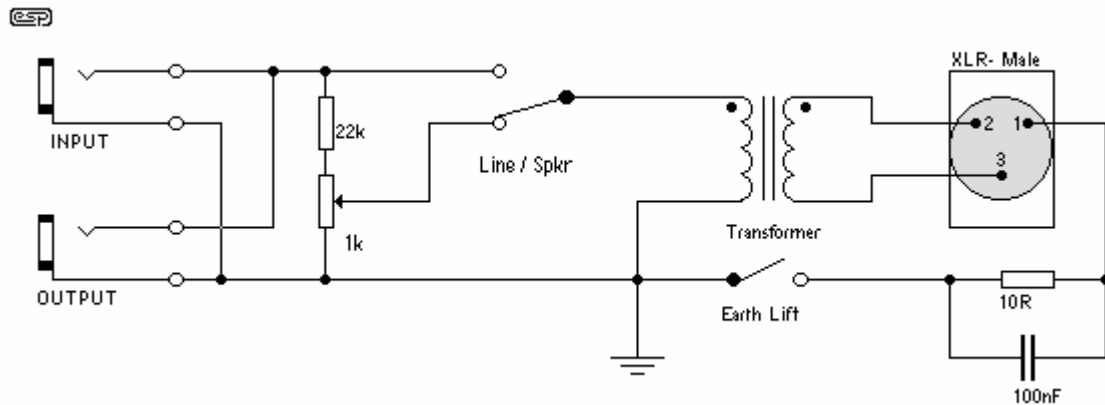

Figure 2 - Passive DI Box

The switch selects either line or speaker level from the phone jacks, and the 1k pot allows you to set the level when using a speaker source. When using speaker input, the attenuator is variable to allow for the widely differing output levels available from amps. No "earth (ground) lift" switch is provided - these are often used to completely isolate the signal source, for those occasions where there is a hum loop created between the mixer and the stage equipment. Instead, there is an earth isolation circuit (the 10Ω resistor and the 100nF cap), which will be more than enough except in the most extreme cases. The earth lift is only fully effective when the transformer circuit is used, and will prove worse than useless in an active unit.

The active unit uses the 48V phantom feed available in many mixers, but can be run from batteries if this is not available. To ensure that there is no unnecessary battery loading a LED has not been included.

The connections to the XLR have been shown on all the drawings, and the pin numbers are clearly marked on the connector, designations are ...

- Pin 1      Earth (Ground)
- Pin 2      Hot (+ve signal)
- Pin 3      Cold (-ve signal)

Note that in some cases (especially with older equipment of US origin), pin 2 is 'cold' and pin 3 is 'hot'. This connection scheme is *not recommended*, and should not be used. The above is as close to an official standard as you will find, and should be used in all cases.



If you want to make the unit phantom or battery only, simply leave out the parts that you don't need. For battery only, you don't need R8 and R9, and D3 (24V zener) can also be omitted. If the unit will only be used with phantom, then you can omit the Phantom/Battery switch and the batteries.